

CONNECT ONLY TO CIRCUITS PROTECTED BY A CLASS A GFCI.

A DISCONNECTING MEANS MUST BE INSTALLED WITHIN SIGHT FROM THE EQUIPMENT AND AT LEAST 5 FEET (1.52 M) FROM THE INSIDE WALLS OF THE POOL, SPA, OR HOT TUB.

ML (MAIN) PANELS
J70, J71 or J72

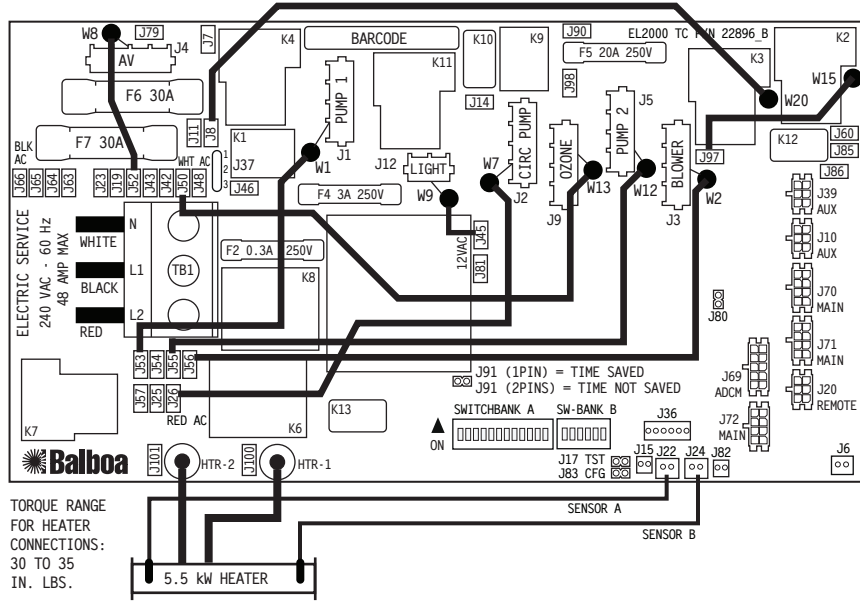

USE COPPER CONDUCTORS ONLY.
EMPLOYER UNIQUEMENT
DES CONDUCTEURS DE CUIVRE.
#6 AWG MIN. WIRE= 75°
FOR SUPPLY CONNECTIONS,
USE CONDUCTORS SIZED ON THE
BASIS OF 60°C AMPACITY BUT
RATED MINIMUM OF 75°C.

TORQUE RANGE FOR
MAIN TERMINAL BLOCK (TB1):
27-30 IN. LBS.

CIRC PUMP BEHAVIOR	A9	A10
NO CIRC PUMP	OFF	OFF
24-HR CIRC	ON	OFF
3°F SHUT-OFF	OFF	ON
FILTERS/POLLS ONLY*	ON	ON

SWITCHBANK A OFF (DOWN)

J83 ON 1 PIN



SWITCHBANK A ON (UP)

TEST MODE OFF	◀ A1	TEST MODE ON
LOW AMP MODE	A2 ▶	HIGH AMP MODE
FILTER BY TIME	◀ A3	FILTER BY DURATION
12 HOUR TIME DISPLAY	◀ A4	24 HOUR TIME DISPLAY
DEGREES F	◀ A5	DEGREES C
15 MIN RUN / P1-LOW 2 HR	◀ A6	30 MIN RUN / P1-LOW 4 HR
CLEANUP CYCLE OFF	◀ A7	CLEANUP CYCLE ON
OZONE SUPPRESSION OFF	◀ A8	OZONE SUPPRESSION ON 1 HR
SEE CIRC BEHAVIOR TABLE	◀ A9	SEE CIRC BEHAVIOR TABLE
SEE CIRC BEHAVIOR TABLE	◀ A10	SEE CIRC BEHAVIOR TABLE
2-SPD P1 - O3 ON W/P1 LOW	◀ A11	1-SPD P1 W/CIRC - O3 IN FILT
STORE SETTINGS	◀ A12	MEMORY RESET

SWITCHBANK B OFF (DOWN)

SWITCHBANK B ON (UP)

PUMP 2 2-SPEED	B1 ▶	PUMP 2 1-SPEED
PUMP 2 DISABLED	B2 ▶	PUMP 2 ENABLED
BLOWER DISABLED	B3 ▶	BLOWER ENABLED
SPA LIGHT	◀ B4	FIBER LIGHT AND COLOR WHEEL
PUMP 3 DISABLED	◀ B5	PUMP 3 ENABLED
PANEL "SCRUNCHING" OFF	◀ B6	PANEL "SCRUNCHING" ON

ALL UNUSED SWITCHES SHOULD BE OFF

LOCATION	DEVICE	VOLTS	AMPS	FROM	TO
J1	2 SPD P1	240V	12A	W1	RED AC
J2	CIRC PUMP	240V	4A	W7	RED AC
J3	BLOWER	240V	8A	W2	RED AC
J4	AV	120V	2A	W8	WHT AC
J5	1 SPD P2	240V	12A	W12	RED AC
J9	OZONE	120V	1A	W13	WHT AC
J12	LIGHT	12V**	2A	W9	J45
HTR	HEATER	240V	5.5kW	HTR TERM	HTR 1/2

**J37 MUST ALSO BE SET ON PINS 2 AND 3 FOR A 12V SPA LIGHT

TOTAL OUTPUT AMP DRAW NOT TO EXCEED MAX INPUT RATING OF SPA
USE EARTH GROUND CONNECTIONS AS INDICATED INSIDE THE SYSTEM ENCLOSURE